



**M**ANY visitors to our extensive works marvel at their size; others, who are familiar with BUICK policies, recognize in our rapid growth only the logical sequence of carefully laid plans. Our policies from the first have been to produce the best cars possible for the price asked, take proper care of customers through our extensive sales organization, and to insure a square deal to all.

BUICK MOTOR COMPANY  
FLINT MICHIGAN

---

---

*"Our Customers Are  
Our Best Salesmen"*

---

---

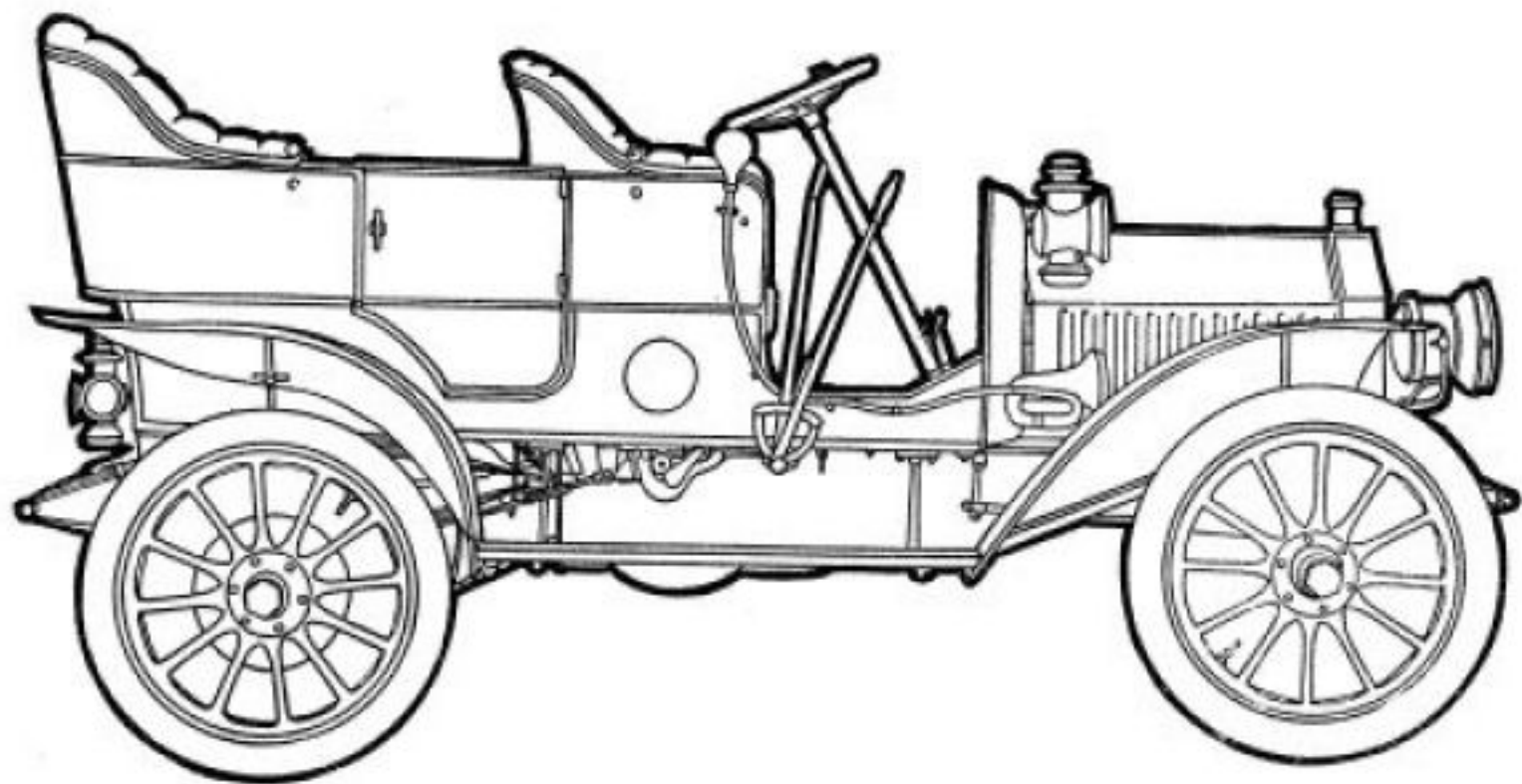

*Buick Model F*

*Price \$1,000*

# BUICK MODEL F SPECIFICATIONS

<i>Body</i> . . . . .	Wood, touring type.
<i>Seats</i> . . . . .	Five persons.
<i>Wheel Base</i> . . . . .	92 inches.
<i>Tread</i> . . . . .	56 inches.
<i>Tires</i> . . . . .	32 x 3½ inches.
<i>Steering Gear</i> . . . . .	Tilting column, pinion and sector type.
<i>Brakes</i> . . . . .	External contracting on differential, and internal expanding hub.
<i>Springs</i> . . . . .	Three-fourths elliptic in front, full elliptic in rear.
<i>Frame</i> . . . . .	Angle iron.
<i>Motor</i> . . . . .	Double opposed. 22 H. P.
<i>Cylinders</i> . . . . .	4½ x 5 inches.
<i>Valve Arrangement</i>	In head of cylinder; cage and valve removable.
<i>Cooling</i> . . . . .	Water, circulated by pump.
<i>Ignition</i> . . . . .	Jump spark.
<i>Lubrication</i> . . . . .	Mechanical force feed lubricator, gear driven.
<i>Carburetor</i> . . . . .	Schebler.
<i>Motor Control</i> . . . . .	Spark and throttle levers on top of wheel on immovable sector.
<i>Transmission</i> . . . . .	Planetary; two speeds forward, one reverse.
<i>Clutch</i> . . . . .	Cone, wide surface, positive action.
<i>Control</i> . . . . .	Pedals for slow speed ahead, reverse and brake; side levers for engagement of clutch and emergency brake.
<i>Drive</i> . . . . .	Chain.

## PRICE

\$1,000 f. o. b. factory. This price includes oil lamps, tail lamp, gas headlights, generator, horn and repair outfit.

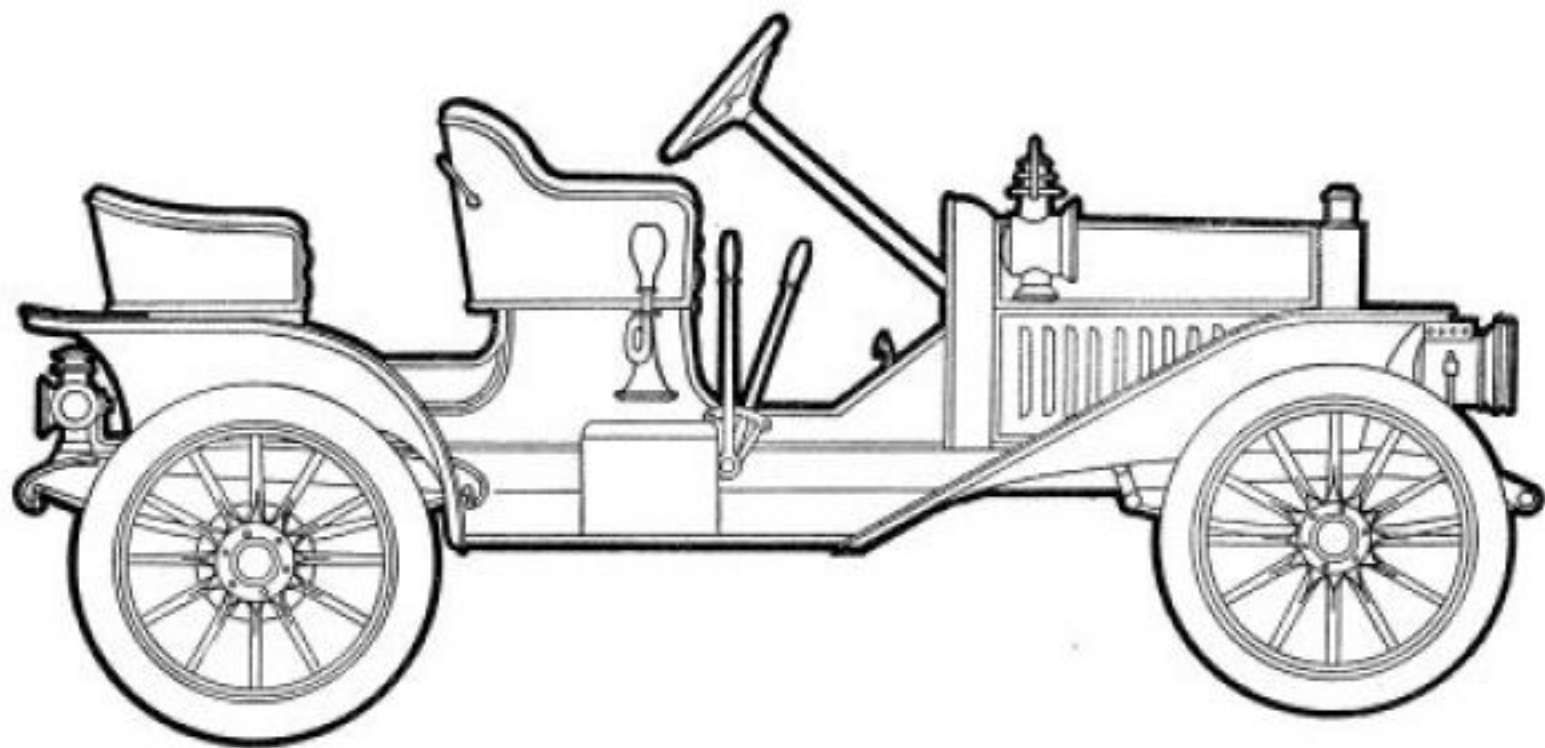

*Buick Model 10 Single Rumble*  
*Price, \$1,000*

# BUICK MODEL 10 SINGLE RUMBLE

<i>Wheel Base</i> . . . . .	92 inches.
<i>Seats</i> . . . . .	Three persons.
<i>Tread</i> . . . . .	56 inches.
<i>Tires</i> . . . . .	30 x 3½ inches.
<i>Brakes</i> . . . . .	Internal expanding hub and external contracting on transmission shaft.
<i>Springs</i> . . . . .	Full elliptic rear, semi-elliptic front.
<i>Frame</i> . . . . .	Pressed steel.
<i>Steering Gear</i> . . . . .	Irreversible type.
<i>Horse Power</i> . . . . .	Eighteen.
<i>Cylinders</i> . . . . .	Four, cast in pairs. Bore 3¾ inches, stroke 3¾ inches. Valve in the head construction.
<i>Motor Suspension</i> . . . . .	Sub-frame.
<i>Cooling</i> . . . . .	Water, circulated by pump.
<i>Ignition</i> . . . . .	Jump spark.
<i>Current Supply</i> . . . . .	The current is supplied by a Remy magneto and a reserve set of dry cells is used for starting.
<i>Carburetor</i> . . . . .	Schebler.
<i>Lubrication</i> . . . . .	Self-contained system, oil circulated by pump.
<i>Motor Control</i> . . . . .	Spark and throttle lever on top of steering wheel.
<i>Clutch</i> . . . . .	Cone.
<i>Transmission</i> . . . . .	Planetary. Two speeds forward, one reverse.
<i>Control</i> . . . . .	Foot pedals for transmission brake, slow speed ahead and reverse; side levers for engagement of clutch and emergency brake.
<i>Drive</i> . . . . .	Shaft.

## PRICE

\$1,000 f. o. b. factory. This price includes oil lamps, tail lamp, generator, gas headlights, horn and repair outfit.

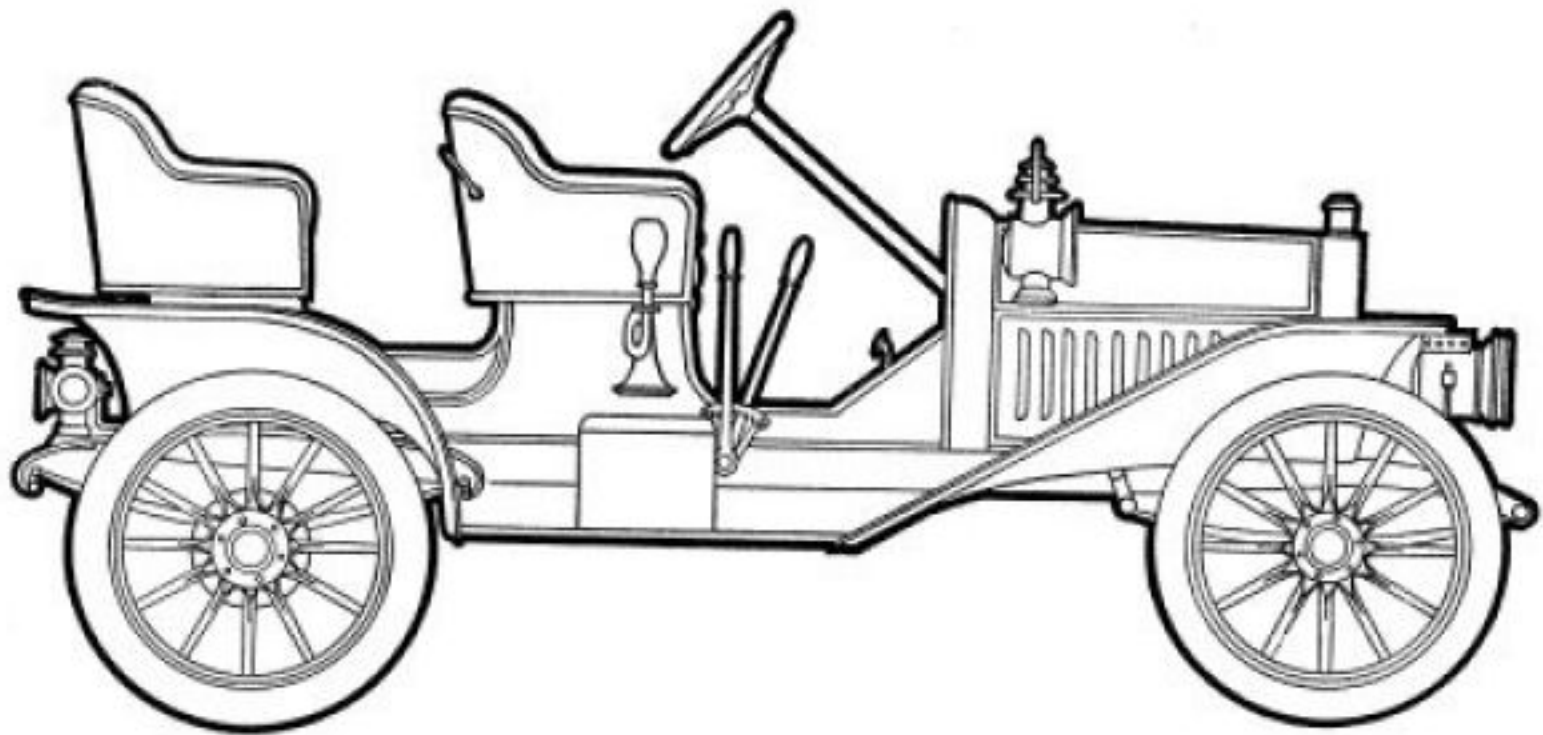

*Buick Model 10 Surrey*  
*Price, \$1,160 10 50*

# BUICK MODEL 10 SURREY

<i>Wheel Base</i> . . . . .	92 inches.
<i>Seats</i> . . . . .	Four persons.
<i>Tread</i> . . . . .	56 inches.
<i>Tires</i> . . . . .	30 x 3½ inches.
<i>Brakes</i> . . . . .	Internal expanding hub and external contracting on transmission shaft.
<i>Springs</i> . . . . .	Full elliptic rear, semi-elliptic front.
<i>Frame</i> . . . . .	Pressed steel.
<i>Steering Gear</i> . . . . .	Irreversible type.
<i>Horse Power</i> . . . . .	Eighteen.
<i>Cylinders</i> . . . . .	Four, cast in pairs. Bore 3¾ inches, stroke 3¾ inches. Valve in the head construction.
<i>Motor Suspension</i> . . . . .	Sub-frame.
<i>Cooling</i> . . . . .	Water, circulated by pump.
<i>Ignition</i> . . . . .	Jump spark.
<i>Current Supply</i> . . . . .	The current is supplied by a Remy magneto and a reserve set of dry cells is used for starting.
<i>Carburetor</i> . . . . .	Schebler.
<i>Lubrication</i> . . . . .	Self-contained system, oil circulated by pump.
<i>Motor Control</i> . . . . .	Spark and throttle lever on top of steering wheel.
<i>Clutch</i> . . . . .	Cone.
<i>Transmission</i> . . . . .	Planetary. Two speeds forward, one reverse.
<i>Control</i> . . . . .	Foot pedals for transmission brake, slow speed ahead and reverse; side levers for engagement of high speed clutch and emergency brake.
<i>Drive</i> . . . . .	Shaft.

## PRICE

\$1,050 f. o. b. factory. This price includes oil lamps, tail lamp, generator, gas headlights, horn and repair outfit.



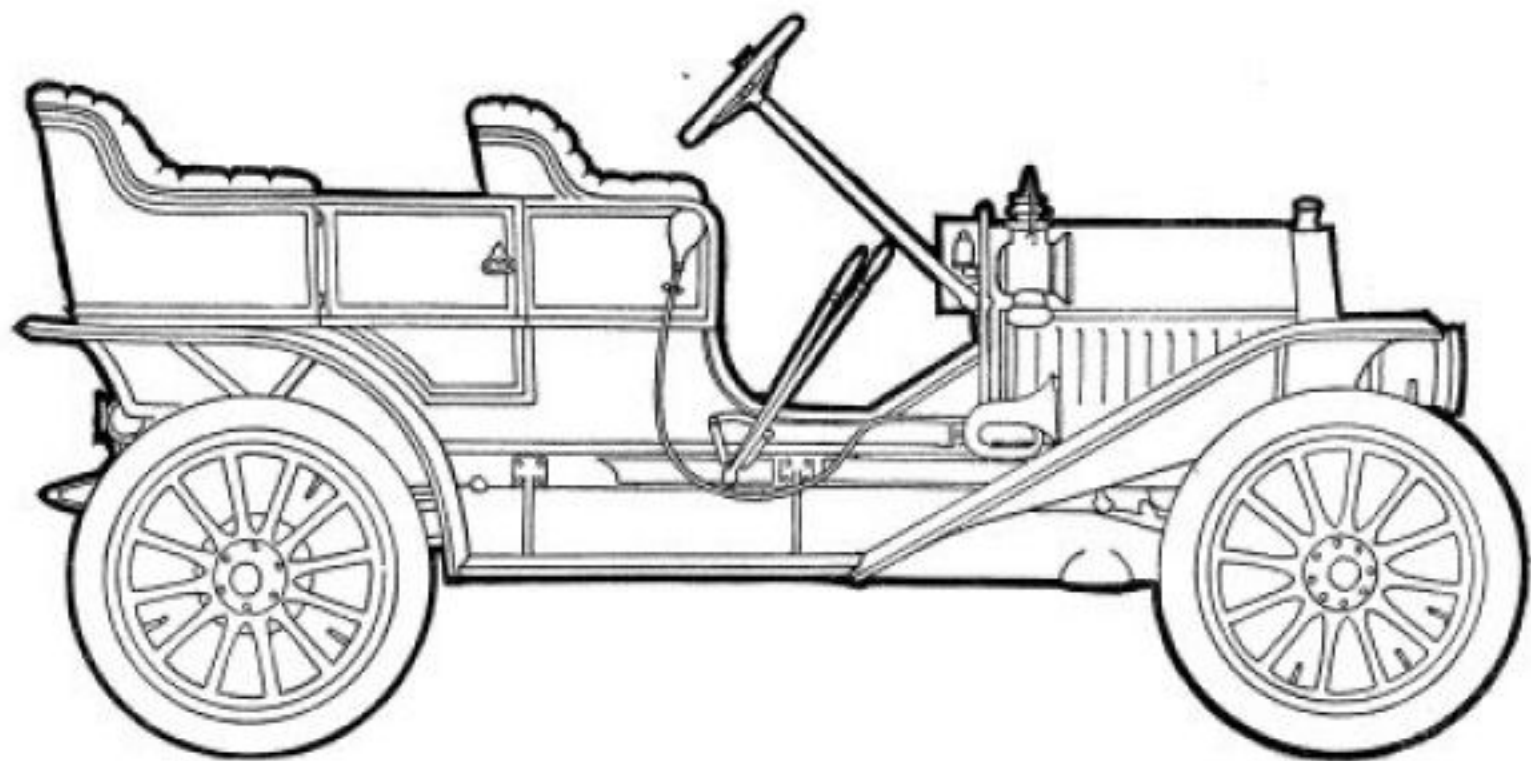

*Buick Model 10 Top Tonneau*  
*Price, \$1,150*

# BUICK MODEL 10 TOY TONNEAU

<i>Wheel Base</i> . . . . .	92 inches.
<i>Seats</i> . . . . .	Four persons.
<i>Tread</i> . . . . .	56 inches.
<i>Tires</i> . . . . .	30 x 3½ inches.
<i>Brakes</i> . . . . .	Internal expanding hub and external contracting on transmission shaft.
<i>Springs</i> . . . . .	Full elliptic rear, semi-elliptic front.
<i>Frame</i> . . . . .	Pressed steel.
<i>Steering Gear</i> . . . . .	Irreversible type.
<i>Horse Power</i> . . . . .	Eighteen.
<i>Cylinders</i> . . . . .	Four, cast in pairs. Bore 3¾ inches, stroke 3¾ inches. Valve in the head construction.
<i>Motor Suspension</i> . . . . .	Sub-frame.
<i>Cooling</i> . . . . .	Water, circulated by pump.
<i>Ignition</i> . . . . .	Jump spark.
<i>Current Supply</i> . . . . .	The current is supplied by a Remy magneto and a reserve set of dry cells is used for starting.
<i>Carburetor</i> . . . . .	Schebler.
<i>Lubrication</i> . . . . .	Self-contained system, oil circulated by pump.
<i>Motor Control</i> . . . . .	Spark and throttle lever on top of steering wheel.
<i>Clutch</i> . . . . .	Cone.
<i>Transmission</i> . . . . .	Planetary. Two speeds forward, one reverse.
<i>Control</i> . . . . .	Foot pedals for transmission brake, slow speed ahead and reverse; side levers for engagement of high speed clutch and emergency brake.
<i>Drive</i> . . . . .	Shaft.

## PRICE

\$1,150 f. o. b. factory. This price includes oil lamps, tail lamp, generator, gas headlights, horn and repair outfit.

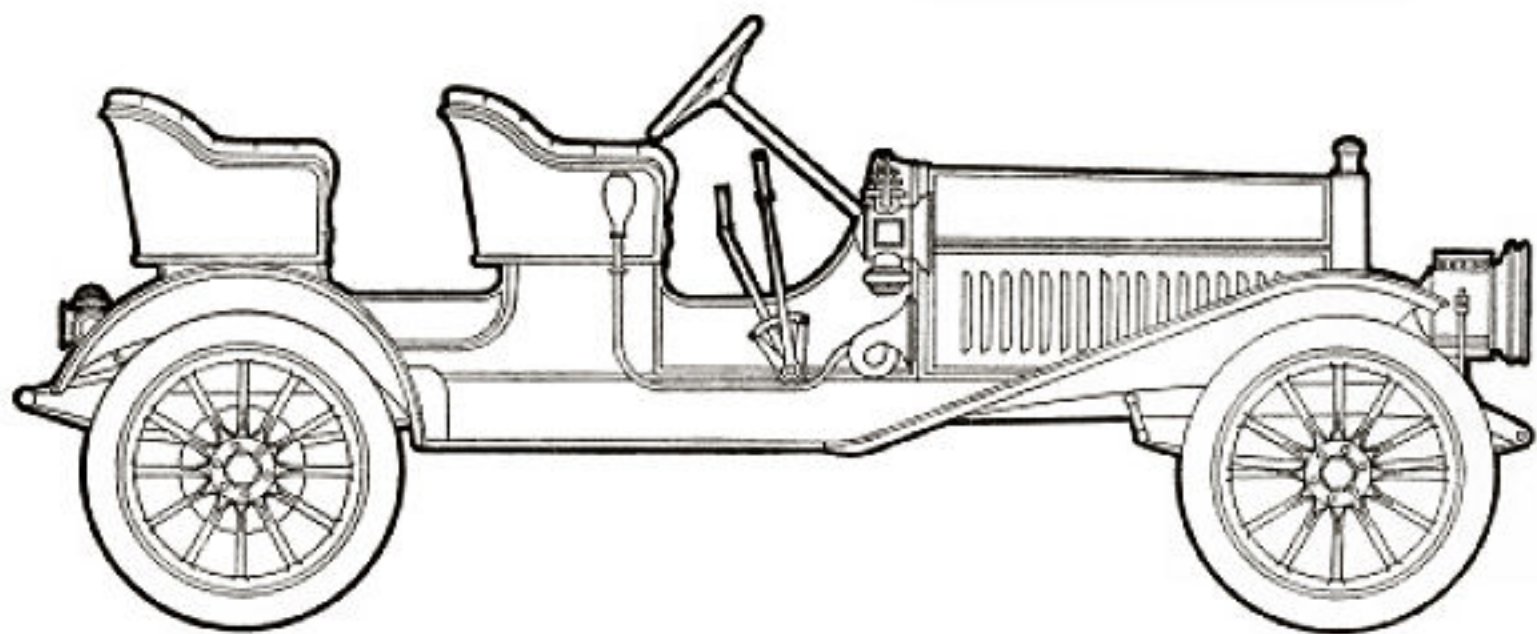

*Buick Model 16*

*Price, \$1,750*

# BUICK MODEL 16 SPECIFICATIONS

<i>Body</i> . . . . .	Wood, tourabout type. Detachable seat and box.
<i>Seats</i> . . . . .	Four persons.
<i>Wheel Base</i> . . . . .	112 inches.
<i>Tread</i> . . . . .	56 inches.
<i>Tires</i> . . . . .	34 x 4 inches.
<i>Brakes</i> . . . . .	Internal expanding hub and external contracting on driving shaft.
<i>Springs</i> . . . . .	Full elliptic rear, semi-elliptic front.
<i>Frame</i> . . . . .	Pressed steel.
<i>Steering Gear</i> . . . . .	Irreversible type.
<i>Horse Power</i> . . . . .	Thirty.
<i>Cylinders</i> . . . . .	Four vertical. 4½ x 5 inches. Valve in the head construction.
<i>Motor Suspension</i>	Sub-frame.
<i>Cooling</i> . . . . .	Water, circulated by pump.
<i>Ignition</i> . . . . .	Jump spark.
<i>Current Supply</i> . . . . .	Magneto and reserve set of dry cells.
<i>Carburetor</i> . . . . .	Schebler.
<i>Lubrication</i> . . . . .	Self-contained system, oil circulated by pump.
<i>Motor Control</i> . . . . .	Spark and throttle levers on top of steering wheel.
<i>Clutch</i> . . . . .	Cone, our special design.
<i>Transmission</i> . . . . .	Sliding gear, selective type; three speeds forward, one reverse.
<i>Control</i> . . . . .	Foot pedals for service brake and clutch; side lever for change gear; side lever for emergency brake.
<i>Drive</i> . . . . .	Shaft.

NOTE—Announcement on Model 16 with Toy Tonneau will be made later

## PRICE

**\$1,750** f. o. b. factory. This price includes oil lamps, tail lamp, generator, gas headlights, horn and repair outfit.  
Extra—Aluminum rear deck with tank, \$50.00 net.

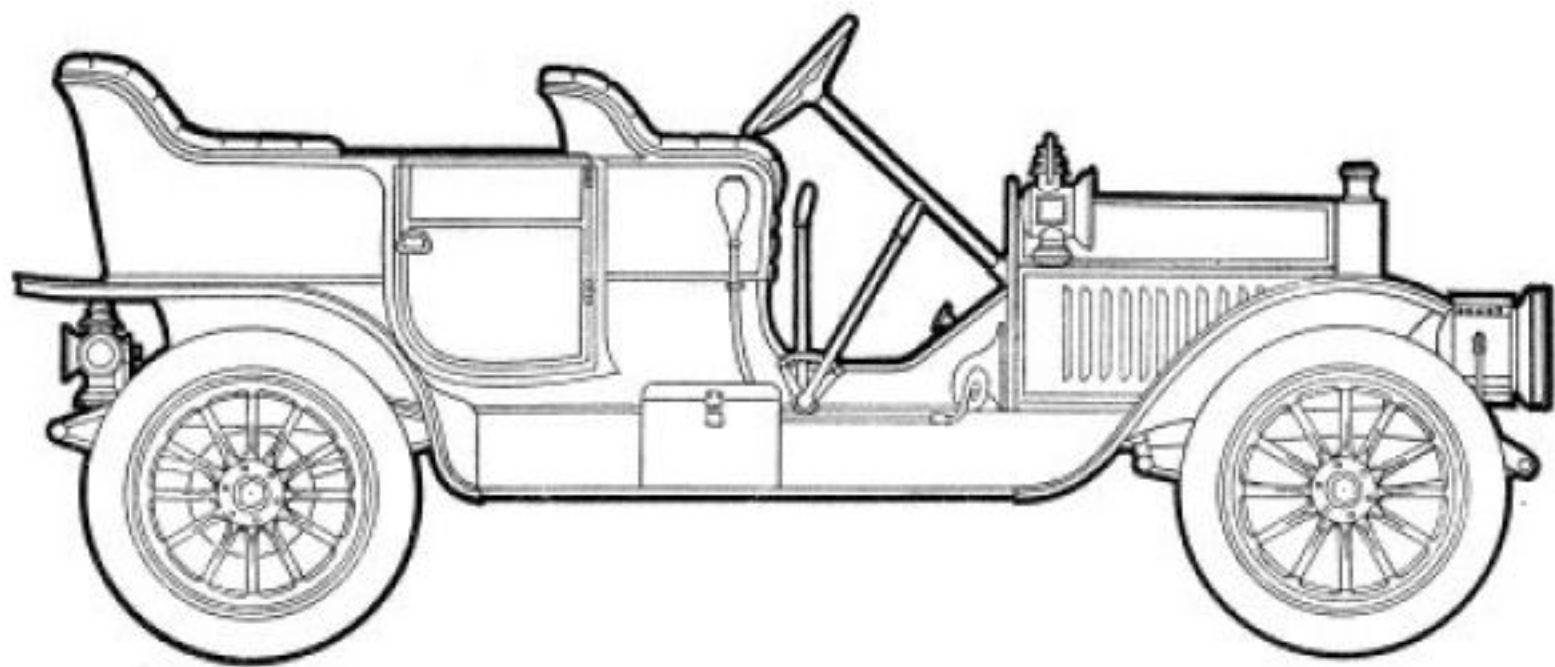

*Buick Model 17*

*Price, \$1,750*

# BUICK MODEL 17 SPECIFICATIONS

<i>Body</i>	Wood, touring type.
<i>Seats</i>	Five persons.
<i>Wheel Base</i>	112 inches.
<i>Tread</i>	56 inches.
<i>Tires</i>	34 x 4 inches.
<i>Brakes</i>	Internal expanding hub and external contracting on driving shaft.
<i>Springs</i>	Full elliptic rear, semi-elliptic front.
<i>Frame</i>	Pressed steel.
<i>Steering Gear</i>	Irreversible type.
<i>Horse Power</i>	Thirty.
<i>Cylinders</i>	Four vertical. 4½ x 5 inches. Valve in the head construction.
<i>Motor Suspension</i>	Sub-frame.
<i>Cooling</i>	Water, circulated by pump.
<i>Ignition</i>	Jump spark.
<i>Current Supply</i>	Magneto and reserve set of dry cells.
<i>Carburetor</i>	Schebler.
<i>Lubrication</i>	Self-contained system, oil circulated by pump.
<i>Motor Control</i>	Spark and throttle levers on top of steering wheel.
<i>Clutch</i>	Cone, our special design.
<i>Transmission</i>	Sliding gear, selective type; three speeds forward, one reverse.
<i>Control</i>	Foot pedals for service brake and clutch; side lever for change gear; side lever for emergency brake.
<i>Drive</i>	Shaft.

## PRICE

\$1,750 f. o. b. factory. This price includes oil lamps, tail lamp, generator, gas headlights, horn and repair outfit.

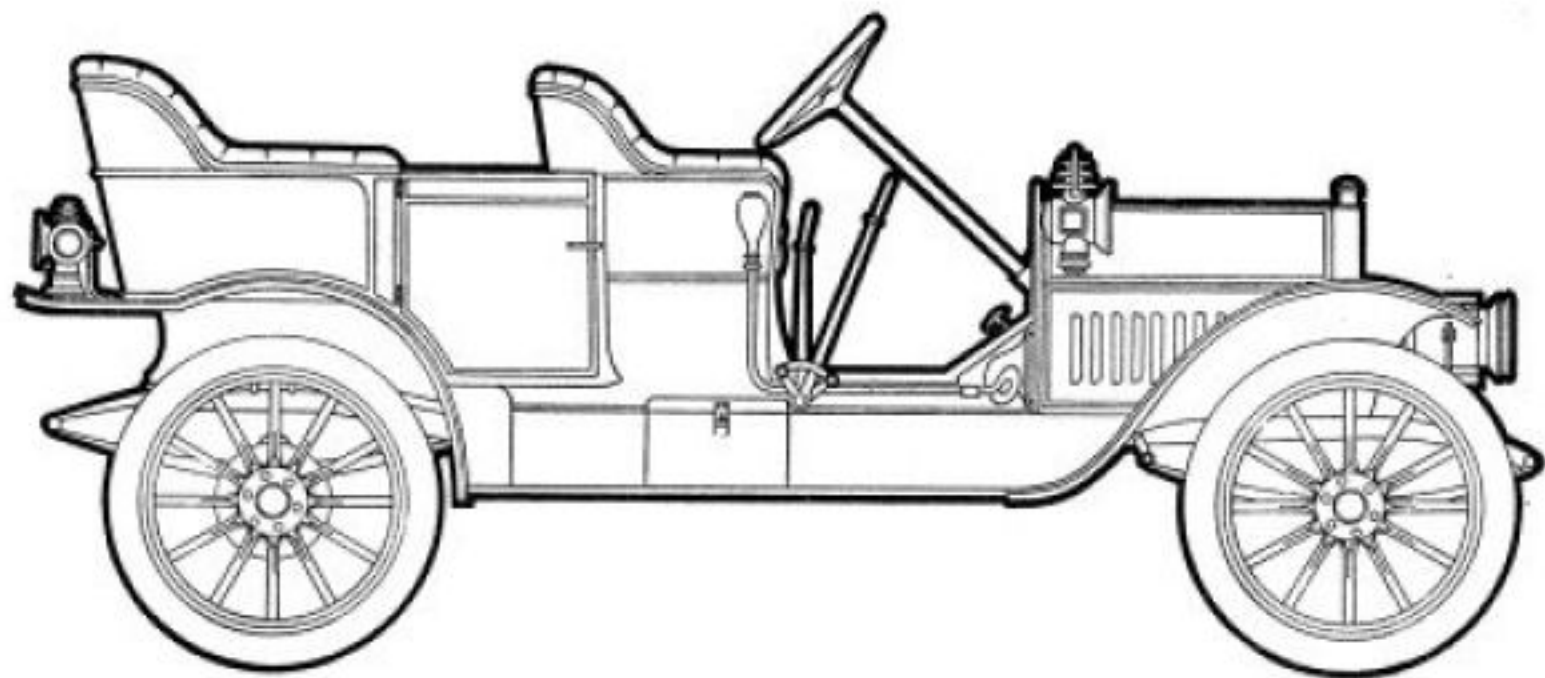

*Buick Model 19*

*Price, \$1,400*

# BUICK MODEL 19 SPECIFICATIONS

<i>Body</i> . . . . .	Wood, touring type.
<i>Seats</i> . . . . .	Five persons.
<i>Wheel Base</i> . . . . .	105 inches.
<i>Tread</i> . . . . .	56 inches.
<i>Tires</i> . . . . .	32 x 4 inches.
<i>Brakes</i> . . . . .	Internal expanding hub and external contracting on driving shaft.
<i>Springs</i> . . . . .	Full elliptic rear, semi-elliptic front.
<i>Frame</i> . . . . .	Pressed steel.
<i>Steering Gear</i> . . . . .	Irreversible type.
<i>Horse Power</i> . . . . .	Twenty-four.
<i>Cylinders</i> . . . . .	Four vertical. $4\frac{1}{4}$ x $4\frac{1}{2}$ inches. Valve in the head construction.
<i>Cooling</i> . . . . .	Water, circulated by pump.
<i>Ignition</i> . . . . .	Jump spark.
<i>Current Supply</i> . . . . .	Magneto and reserve set of dry cells.
<i>Carburetor</i> . . . . .	Schebler.
<i>Lubrication</i> . . . . .	Self-contained system, oil circulated by pump.
<i>Motor Control</i> . . . . .	Spark and throttle levers on top of steering wheel.
<i>Clutch</i> . . . . .	Cone, special design.
<i>Transmission</i> . . . . .	Sliding gear, selective type; three speeds forward, one reverse.
<i>Control</i> . . . . .	Foot pedals for service brake and clutch; side lever for change gear; side lever for emergency brake.
<i>Drive</i> . . . . .	Shaft.

## PRICE

\$1,400 f. o. b. factory. This price includes oil lamps, tail lamp, generator, gas headlights, horn and repair outfit.