

ATWATER KENT

*Starting and Lighting
System*

for

FORD Touring Cars and Roadsters

(with new-style engine)

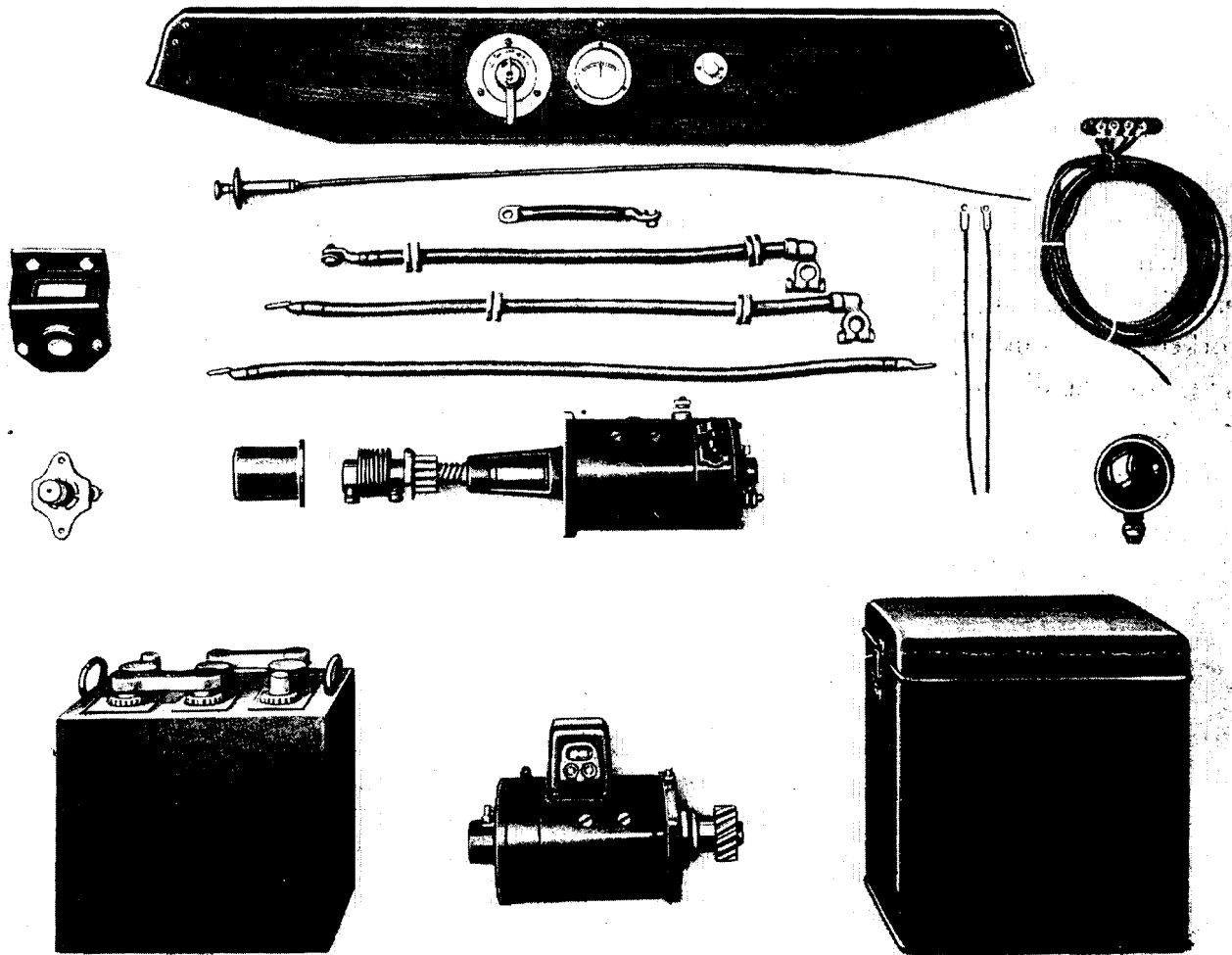

THIS equipment has been produced to meet the large and growing demand for a high-grade, dependable starting and lighting system for the new-style Ford.

Every 1919 Ford touring car or roadster, designed to carry electrical equipment and not factory equipped, means a valuable sales opportunity for the dealer—and Atwater Kent

*Atwater Kent
Generator*

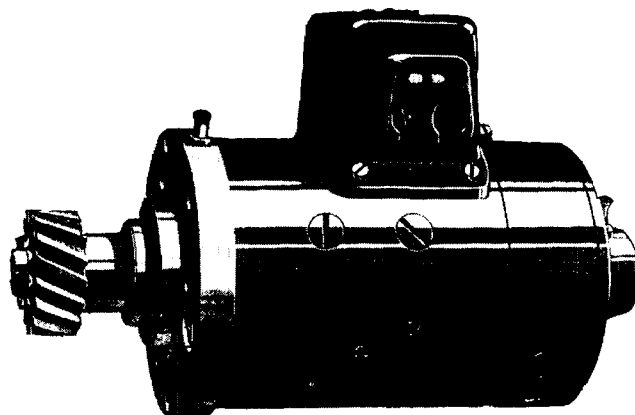

quality means complete satisfaction for the motorist.

Gruelling tests have proven that this new addition to the Atwater Kent line is of the same high quality which has characterized all their earlier products. Every detail of material, finish and workmanship has been worked out from the "quality-first" standpoint and rigidly held to the Atwater Kent Standard.

The system is of the six-volt single wire type and combines the best of standard practice with several unique features which mark a distinct advance in starting and lighting equipment.

The first among these improvements on present-day practice is the Atwater Kent Generator, which automatically varies its current output to meet the varying requirements of motoring. A car driven mostly at night obviously demands a larger output from the generator than one generally used in daylight. The usual type of generator which will take care of the night driver's heavy demands for lighting current has too great an output for the daylight driver. The ordinary generator is designed to strike an average between these two

requirements. In consequence, the storage battery, the keystone of the whole system, is constantly undercharged on one car and overcharged on another. In the Atwater Kent system, when the lights are thrown on, the generator automatically delivers a larger current supply and the battery gets under all conditions its proper charge. This one feature ensures long life for the battery and low upkeep cost.

The output chart, Fig. 1, illustrates very clearly the even charging rate obtained by the use of this unique Atwater Kent feature.

An automatic cut-out is mounted on the top of the generator. This operates as an "electrical check-valve," automatically connecting the generator and the storage battery when sufficient current is being generated to charge the battery. It also automatically opens, preventing any reverse flow when the generator voltage falls below that of the battery.

A small fuse mounted on the cut-out box protects the generator windings from excessive current.

The generator is fitted with high-grade ball-bearings for easy, quiet operation. Two or

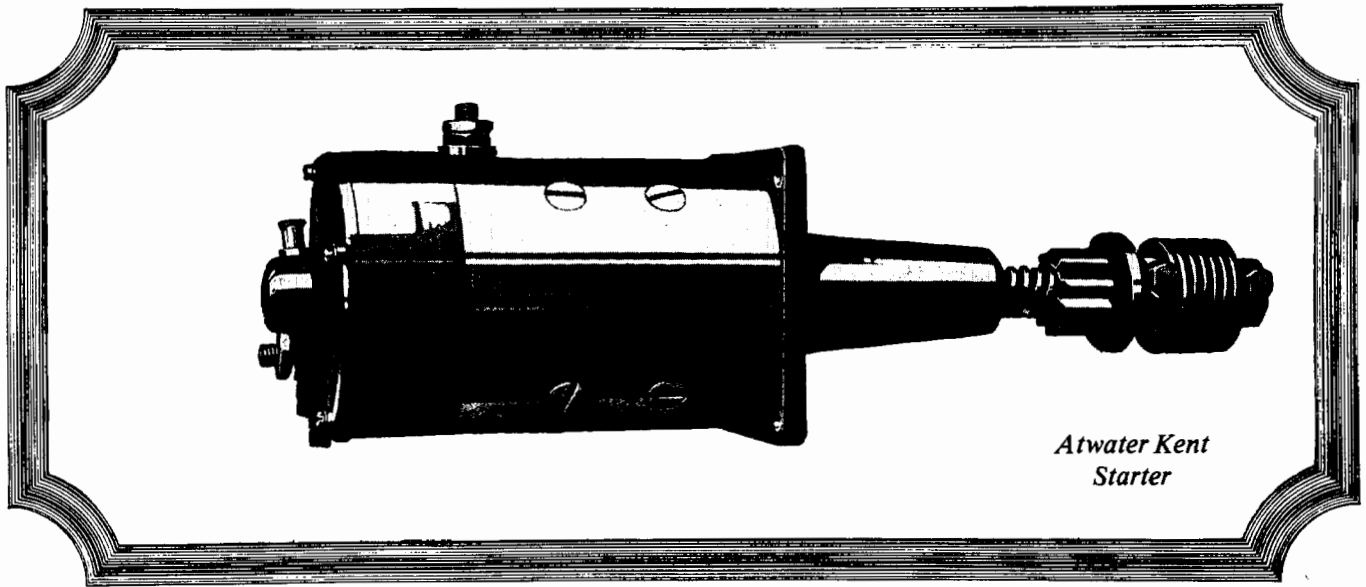

*Atwater Kent
Starter*

three drops of oil every two thousand miles ensures perfect lubrication.

The starting motor of the series-wound type is sturdy and compact, and tested to crank the stiffest engine under the most unfavorable conditions of winter driving. Brushes and commutator are of large size, easily accessible, and completely protected by a removable dustproof cover. A standard Bendix drive is used to engage the starting motor with the engine.

Two drops of oil every two thousand miles will keep the starting motor perfectly lubricated.

The storage battery supplied is an "Exide" of eighty ampere hour capacity. This battery has been selected from a large field because of our knowledge of its sturdiness and reliability. Its excellent construction, coupled with the even charging rate maintained by the Atwater Kent generator, assures perfect service and economy.

All minor parts of the system are tested to the same high standard as the major units. The use of a high-grade ammeter and an extra-heavy carburetor choke lever is simply an

example of the "quality-first" policy pursued throughout the entire system.

The outfit comes to the purchaser absolutely complete from the tail light and bulb to the smallest screw necessary for the installation. The price, **NINETY-SEVEN DOLLARS COMPLETE**, includes every item which is used in making the installation. **THERE ARE ABSOLUTELY NO EXTRAS OF ANY SORT TO BUY.**

Careful planning at the factory has made the installation a simple matter. All wiring connections are already made to the switch and ammeter, and these come mounted on the high-grade instrument board furnished with the outfit. Nuts, bolts and washers are temporarily attached to the parts to which they belong to avoid any chance of loss or confusion. A carefully prepared instruction book, with twenty illustrations covering every operation in detail, is packed with each system.

Improper installation, and the trouble it involves for both dealer and purchaser, are impossible if these directions are followed.

Especially attention has been devoted to the question of packing the outfit for shipment.

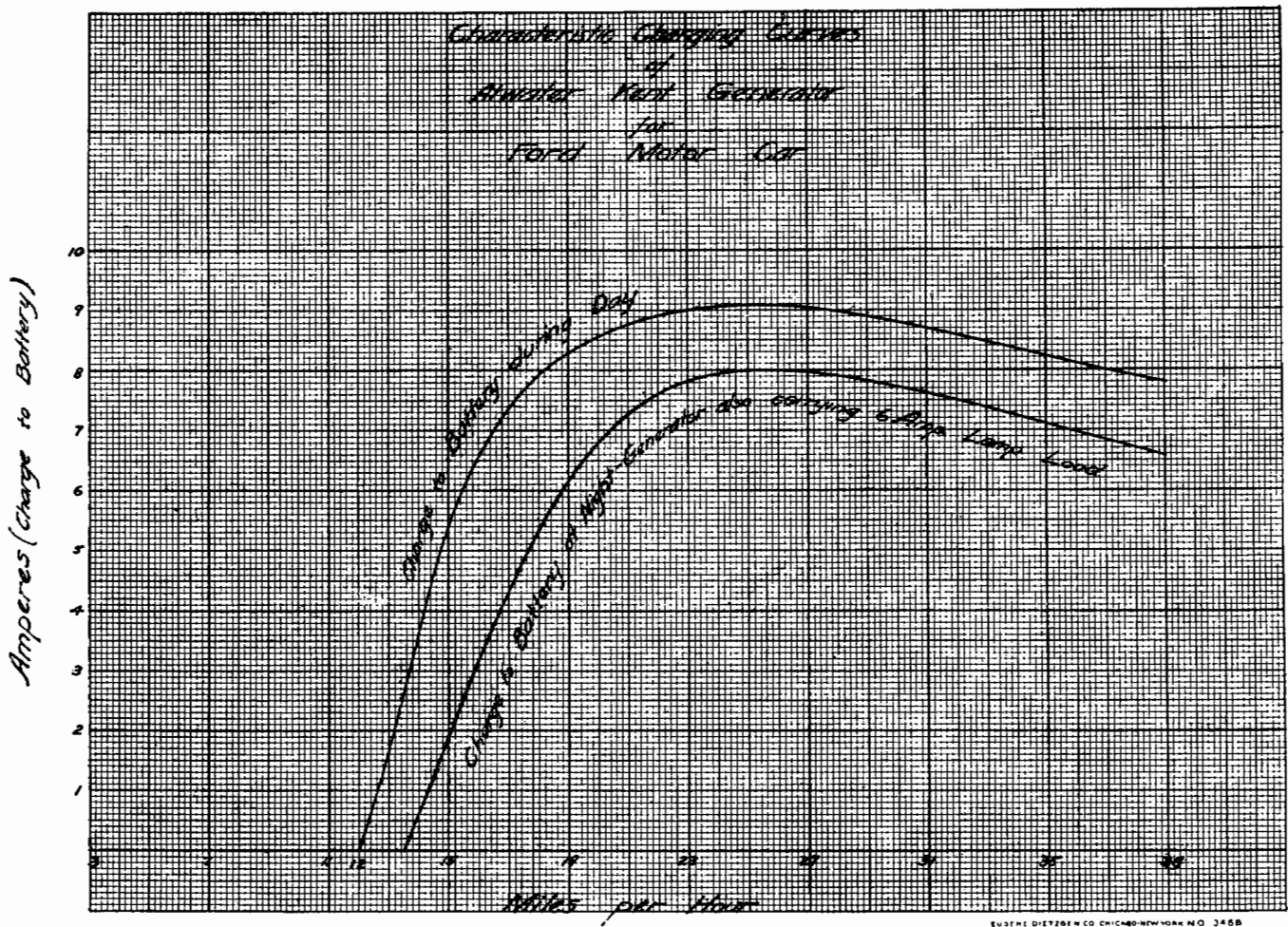

After numerous experiments, a packing case and battery case have been designed which will ensure the arrival of the outfit in perfect condition. Without undue increase in shipping weight, the chances of loss or breakage while enroute to the purchaser have been reduced to a minimum, and the consequent delays and annoyances attending claims for shortage, etc., virtually eliminated.

Both the generator and starting motor are interchangeable with units installed on the 1919 Sedan at the Ford factory. These units can be bought separately and can be installed without difficulty by following the printed instruction book sent with each shipment. This opens to the dealer a wide field in the sale of Atwater Kent units for replacement purposes.

The outfit as shipped weighs 157 pounds and comprises the following items:

- Generator, with cut-out, fuse and driving gear complete.
- Starting motor with Bendix drive and housing complete.
- Storage battery, "Exide," eighty ampere hour.
- Battery Box.
- Combination lighting and ignition switch.
- Instrument board and ammeter.
- Electric tail lamp and bulb.
- Carburetor choke lever, extra heavy.
- Starting switch and starting cables.
- Lighting wires.
- Bolts, nuts, screws, washers and staples (complete set as used in installation).
- Instruction book.

OUTFIT COMPLETE AS ABOVE . . . \$97.00

ATWATER KENT STARTING AND LIGHTING FOR 1919 FORDS

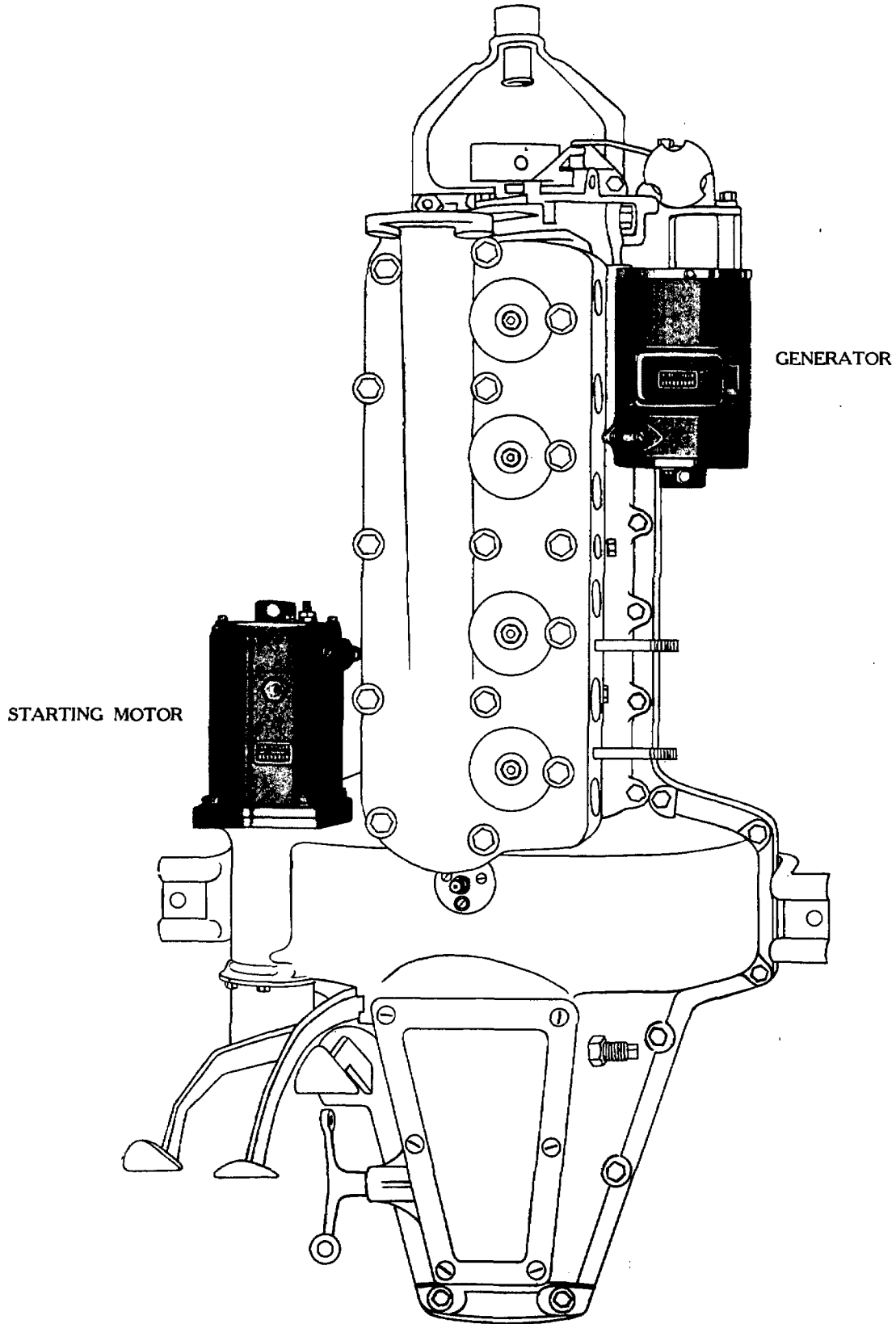

FIG. 1

ATWATER KENT STARTING AND LIGHTING SYSTEM INSTALLED ON NEW STYLE 1919 FORD MOTOR

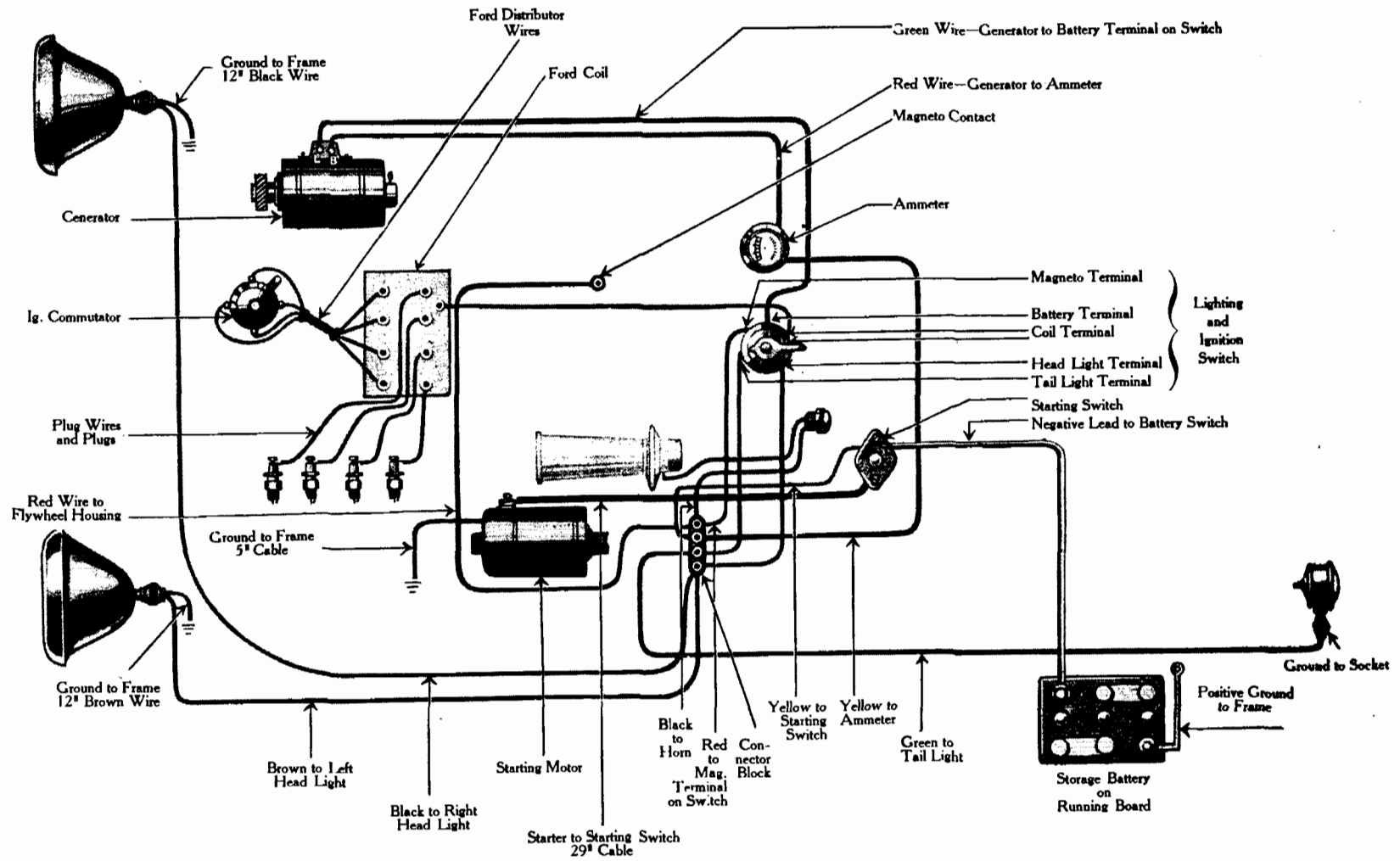

FIG. 2

ATWATER KENT STARTING AND LIGHTING SYSTEM WIRING CONNECTIONS ON NEW STYLE 1919 FORD MOTOR

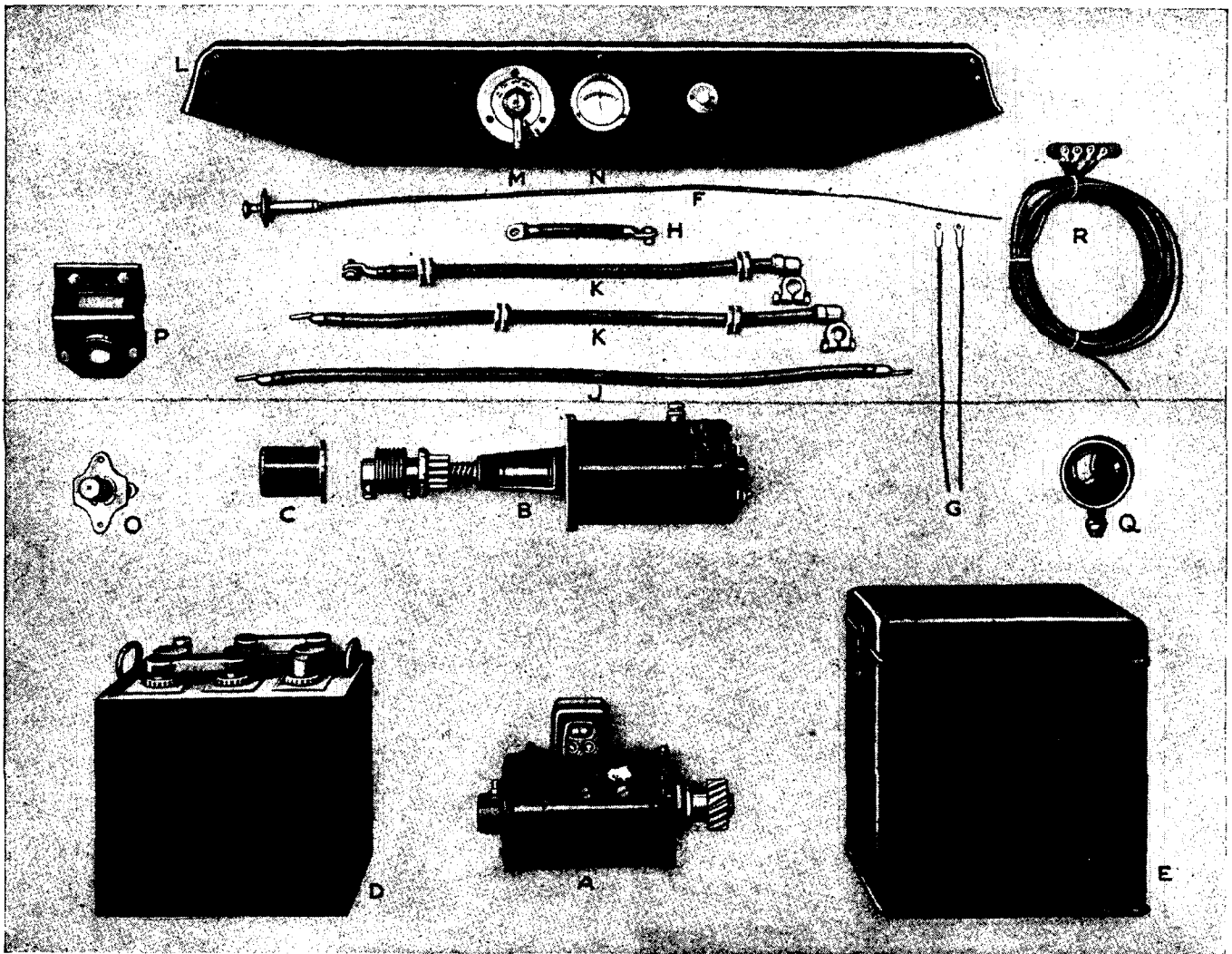

FIG. 3

MATERIALS FURNISHED

THE articles listed below are checked at the factory before being sent out. Take especial care that none of the small parts are lost in unpacking. The larger items are displayed in Fig. 3. The various nuts, bolts, washers, etc. (all marked * in the list are not illustrated, but can easily be identified). The wiring is shown as it is packed in cables containing two, four and five wires, respectively.

A— Generator	1	M— Lighting and Ignition Switch	1
B— Starting Motor with Bendix.....	1	N— Ammeter	1
C— Bendix Cover	1	O— Starting Switch	1
D— Storage Battery	1	*— Starting Switch Nuts and Screws.....	2
E— Battery Box	1	P— Switch Bracket	1
F— Carburetor Choke	1	*— Switch Bracket Nuts, Bolts and Washers..	2
*— Carburetor Choke Screws.....	2	R— Connector Block	1
G— Headlight Ground Wires.....	2	Q— Tail Lamp with Bulb.....	1
H— Starting Cable, 5 inches.....	1	*— Insulated Staples	20
J— Starting Cable, 27 inches.....	1	*— Dimmer (attached to Switch).....	1
K— Battery Leads with Terminals and Lugs..	2	*— Manual of "Exide" Batteries.....	1
L— Instrument Board, containing.....	1	*— Instruction Book	1

TOOLS REQUIRED

Screw driver.
Hammer.
Ford angle socket wrench.
Open end wrench for 5/16-inch bolts.
Open end wrench for 5/16-inch nuts.
Open end wrench for 1/4-inch bolts.
Open end wrench for 1/4-inch nuts.
Brace or breast drill.
3/8-inch, 1/2-inch, 5/8-inch bits.

INTRODUCTORY NOTE

Read over these instructions carefully and install each unit in the exact order laid down in these pages. When "right" and "left" are mentioned in the directions, these words refer to the driver's right and left when seated at the wheel.

TO PUT ON THE GENERATOR

NOTE.—It is not necessary to drop the engine pan in order to insert the generator.

1. Take off disc on the rear of front gear case by taking off the three nuts.
2. Leave the bolts, which project through the entire gear case, in place. They are used to hold the generator.
3. Leave the paper gasket in position.
4. Put pinion end of generator into the hole uncovered when disc is removed.
5. See that cut-out box is vertical.
6. Put on one bolt to hold generator temporarily. Rotate generator slightly to right and left until the threads of the bolts catch.
7. Tighten bolts with fingers as much as possible. Then draw up each bolt evenly, one turn to each nut in succession until tight.
8. Inspect joint thus formed between generator and gear case to make certain that the surfaces are firm and square.

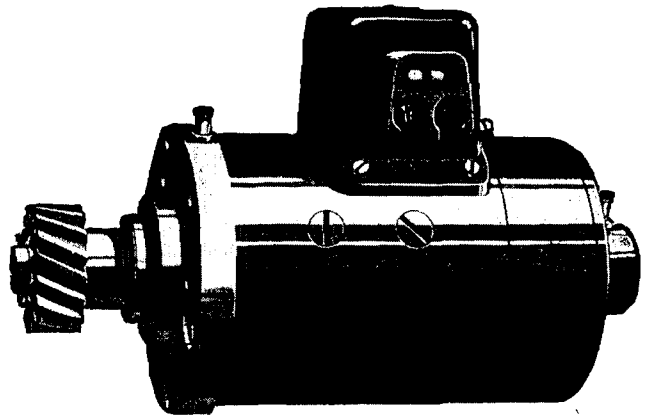

FIG. 4
GENERATOR

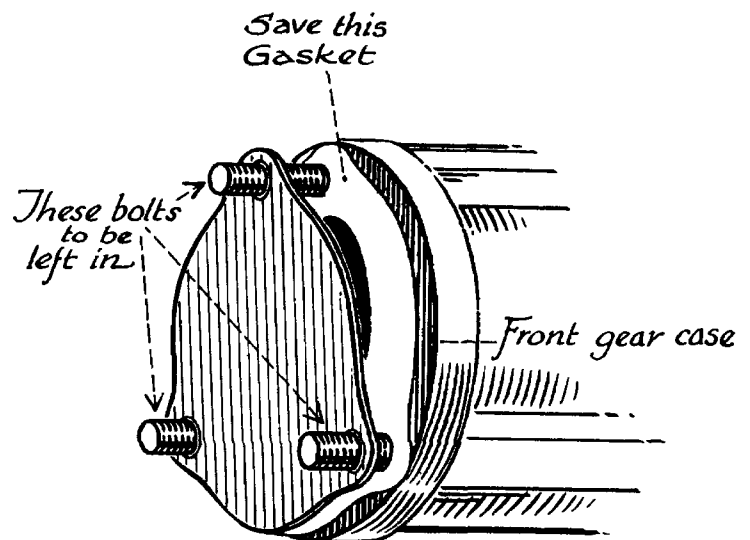

FIG. 5
REMOVING DISC ON GEAR CASE

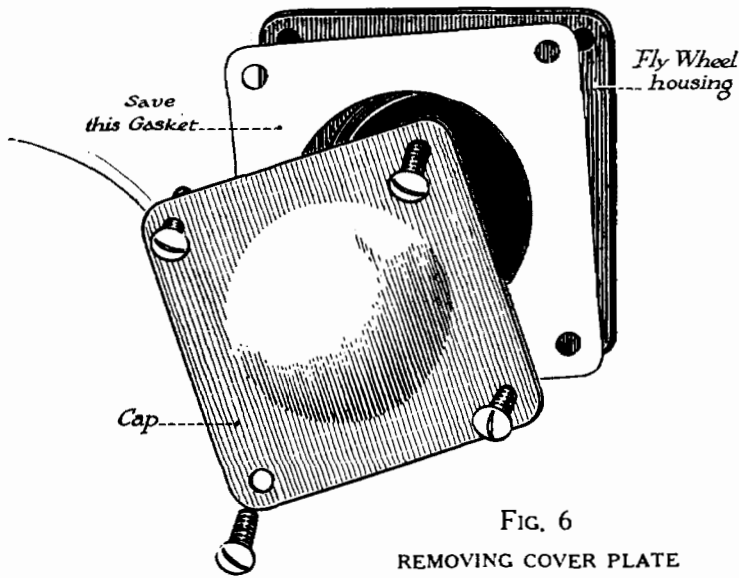

FIG. 6
REMOVING COVER PLATE

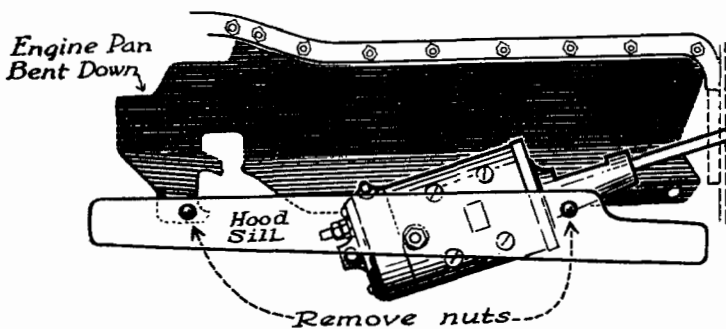

FIG. 7
INSERTING STARTING MOTOR

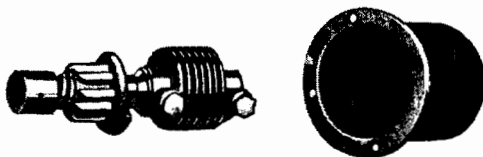

FIG. 8
BENDIX DRIVE AND COVER

TO PUT ON STARTING MOTOR

1. Remove the square, thin cover plate at the left and in front of the flywheel housing, Fig. 6. This is done by taking out the four round-headed machine screws.

2. Save this gasket carefully for use a little later on.

3. Remove the round cover plate on other side of flywheel housing. This is done by taking out the four round-headed machine screws.

4. Carefully save this gasket for use a little later.

5. Unloosen engine pan on left-hand side by taking off the two square nuts found under the sill, near each end of the pan. The bolts holding the pan pass through the frame and pan.

6. Bend down pan until there is room to slip starting motor through from underneath the car, Fig. 7.

7. Remove bendix starter gear from end of starting motor by taking out the set screw in end of shaft.

8. Point starting motor into hole in flywheel housing.

9. Push starting motor as far as possible through flywheel housing until flange of starting motor is flush against square surface of front side of flywheel housing, being careful to replace gasket, making certain that the surfaces between which the gasket fits are clean.

10. Bring top binding post of starting motor to vertical position at top.

11. Rotate motor slightly right and left until the four 5/16-inch screws can be started.

12. Pull up these screws evenly, one turn at a time.

13. Holding spring end in the hand, slip the bendix starter gear on the shaft, which now projects through the rear of the flywheel housing.

14. Be sure that Woodruff key is in the end of shaft.

15. Slide the driving piece on the shaft, being careful to fit tang into slot.

16. Bring the set screw of this piece directly over the set screw hole in the shaft.

17. Pull the set screw down tightly into the eye of the spring.

18. The lip of the lock washer, already bent down, fits into the spring eye.

19. Bend the other lip up along the flat of the set screw.

20. Put on cup-shaped starter gear cover, Fig. 8, using gasket previously removed from the round cover plate.

INSTALLING STARTING SWITCH

1. Starting switch pedal projects through the $1\frac{1}{4}$ -inch hole in floor board just under driver's left heel.

2. Fasten switch to bracket with the two $\frac{1}{4}$ -inch bolts.

3. Bracket in turn fastens to the frame by the two $\frac{5}{16}$ -inch bolts.

4. Pass these through the two holes already drilled in the upper angle of the frame just under the hole for starting pedal in the floor board.

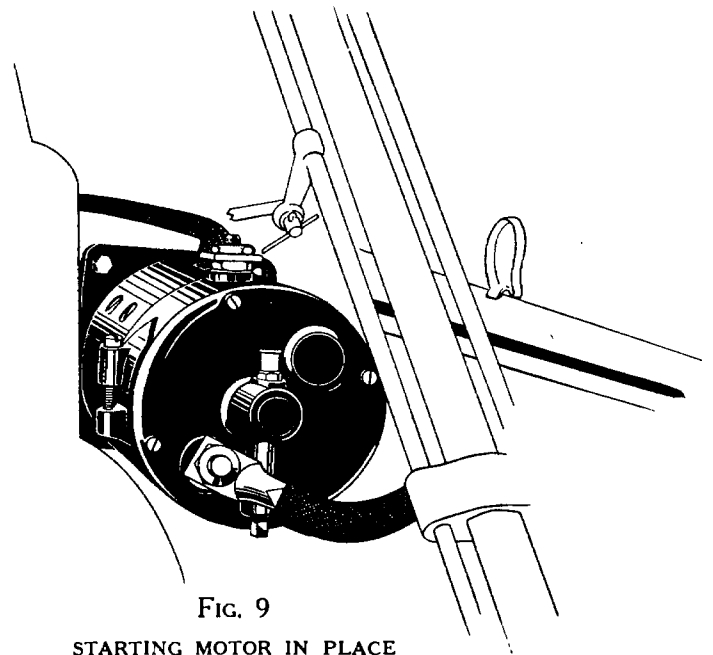

FIG. 9
STARTING MOTOR IN PLACE

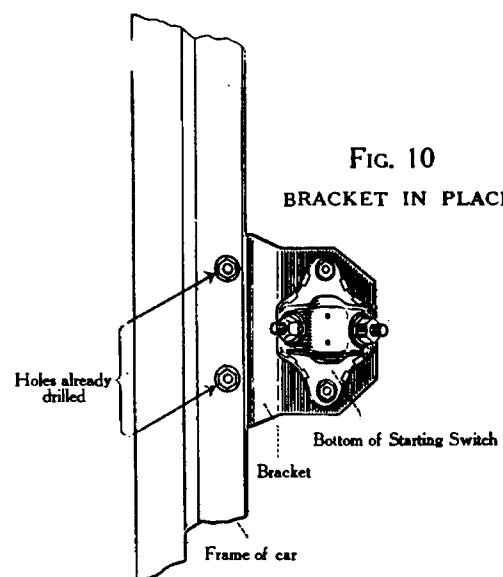

FIG. 10
BRACKET IN PLACE

DO NOT CONNECT UP BATTERY UNTIL THE VERY LAST

1. Pass the positive lead through the right-hand or rear hole.
2. Work the first rubber grommet into the hole in the apron.
3. Work the other grommet into the hole in the battery box.
4. Pass the negative lead through the left-hand or front hole.
5. Work in the grommets in the manner described above.
6. Connect copper terminal of the negative lead to the outside binding post of the starting switch. (There should already be a yellow wire from the connector block at this point.)
7. Connect copper terminal of positive lead to frame of car by the $\frac{1}{4}$ -inch bolt furnished with the system.
8. This bolt goes into hole already drilled in lower angle of frame, directly in line with battery box.
9. Push down the lead terminals on the binding posts of the battery.
10. Clamp with clamp screw in the terminal.

NOTE.—See that conical battery lugs are inside of terminal connections and are absolutely clean.

FINAL NOTE

Go over entire system to see if all screws are drawn up tight and that all wiring connections are firm.

CARE OF BATTERY

The directions given in the battery instruction book furnished with the system should be followed very carefully. The largest part of lighting and starting difficulties can be traced to the battery. These difficulties are practically always caused by failure to follow the directions for the care of the battery. "A stitch in time" here will save at least nine later on.

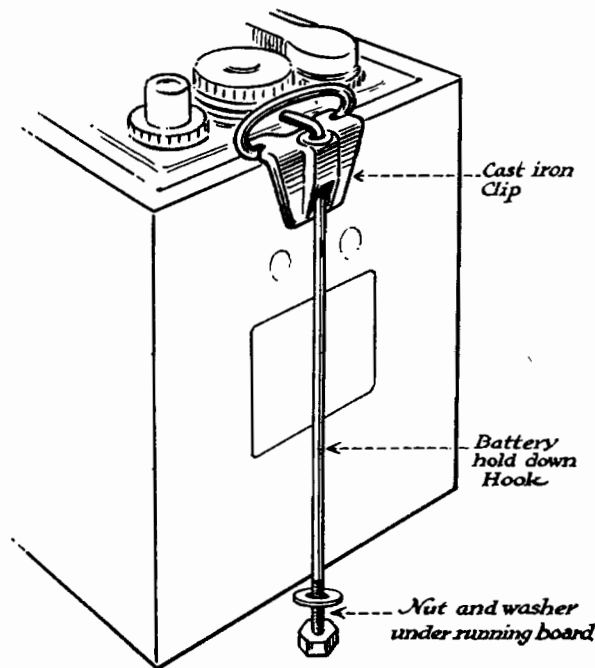

FIG. 19

FASTENING BATTERY AND BOX

INSTALLING INSTRUMENT BOARD

1. Remove the clamps.
2. Set the instrument board flush against the lower angle of the windshield with the two ends against the windshield supporting casting.
3. Attach the two end clamps over the windshield supporting casting and draw up tightly.
4. Attach the center clamp over the lower angle of the windshield.

CARBURETOR CHOKE

1. Place carburetor choke in the $\frac{1}{2}$ -inch hole in instrument board at the right of the ammeter.
2. At the same time, guide the brass tubing through the $\frac{3}{8}$ -inch hole drilled at an angle of 45 degrees in the dash.
3. Bend the tubing into an easy curve, being careful not to kink it at any point.
4. Fasten tubing with clip under the $\frac{3}{8}$ -inch manifold clamping screw, under which hot-air horn of carburetor is already clamped.
5. Into lower and empty arm of carburetor choke lever put the $\frac{1}{8}$ -inch cotter pin furnished with the outfit.
6. Spread pin so that spread end is nearest the carburetor.
7. Put pin or nail in eye of cotter pin and rotate pin to make certain that it is free to turn.
8. Pass through eye of cotter pin brass wire which works inside of tubing.
9. With carburetor choke lever in normal running position, bend the brass wire, with round-nosed pliers, to form a right-angle open bend, as shown in Fig. 15.
10. Screw dash choke control tight to instrument board by means of the round-headed nickel-plated screws.

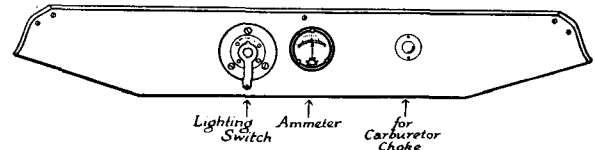

FIG. 13
INSTRUMENT BOARD

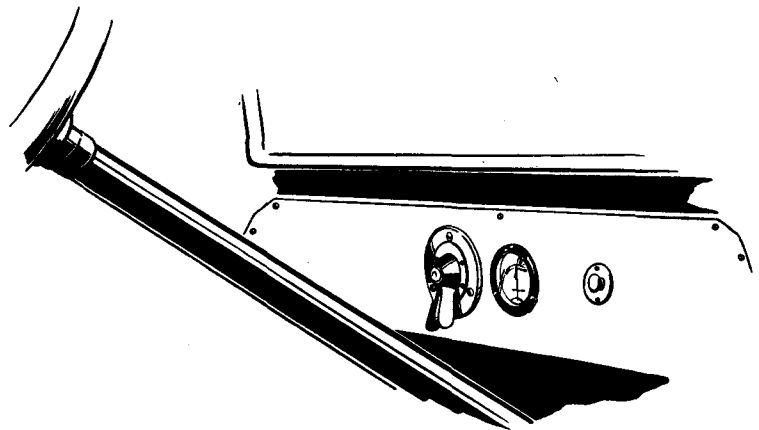

FIG. 14
INSTALLATION OF INSTRUMENT BOARD

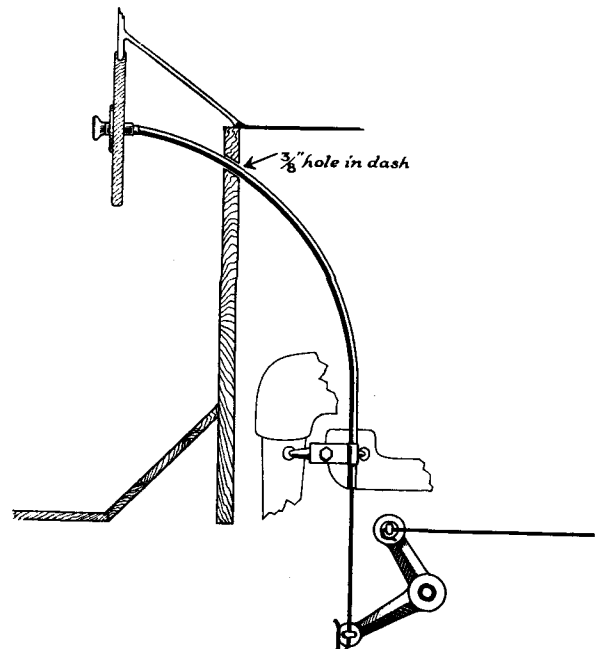

FIG. 15
INSTALLATION OF CARBURETOR CHOKE

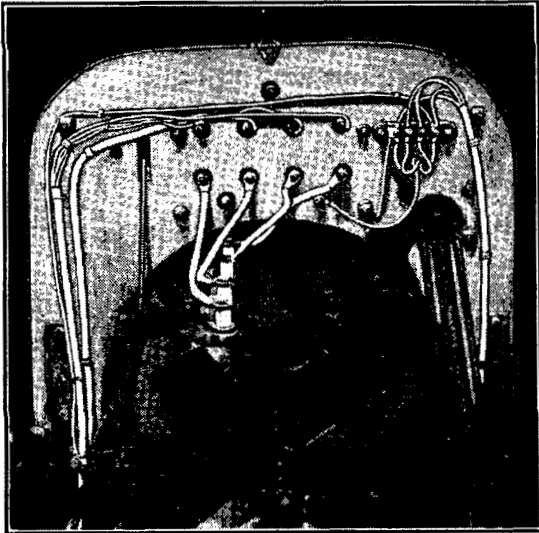

FIG. 16
WIRING ON DASH COMPLETED

WIRING INSTRUCTIONS

Important: Wherever wires are held down by staples, be very careful not to drive the prongs through the insulation.

CONNECTING UP GENERATOR

1. Pass the free end of the two-wire cable through the $\frac{1}{2}$ -inch hole drilled at the right of the dash.
2. Tack down the cable to dash as shown in Fig. 16, bending cable at the frame and running it forward to the generator.
3. At frame fasten cable under metal clips already holding wires to Ford distributor.
4. Connect red wire to terminal marked "B" on terminal block of generator.
5. Connect green wire to terminal marked "L."

CONNECTING UP STARTING MOTOR

1. Fasten the heavy starting cable 27 inches long (two copper terminals exactly alike) under the starting switch terminal toward the center of car.
2. Fasten the other end of this cable to the top binding post of the starting motor, being careful to lock the nut with the lock-washer.
3. Fasten one end of the smaller starting cable, five inches long, to the end binding post of the starting motor.
4. Fasten the other end to the frame by means of the $\frac{1}{4}$ -inch bolt.
5. Pass this bolt through the hole already drilled in the lower leg of the channel of the frame.

CONNECTING UP FOUR-WIRE CABLE

1. Connect up the free ends of the four-wire cable as follows:
2. Lead the brown wire along left hood sill to left headlight, tacking it to the wooden blocks along the sill.
3. Connect red wire to Ford magneto terminal at the top of flywheel housing.
4. Lead yellow wire along body sill toward rear and connect to outside terminal of starting switch.
5. Lead green wire along body sill to rear and connect to tail light.

CONNECTING UP FIVE-WIRE CABLE

1. Pass free ends of five-wire cable through $\frac{5}{8}$ -inch hole drilled at left of dash.
2. Fasten the black wire to the left-hand binding post of the Ford coil.
3. Connect the other wires to binding posts of connector block, being careful to use the lock washers.
4. Connect the red wire to the binding post already carrying one red and one black wire.
5. Connect the green wire to the binding post already carrying a green wire.
6. Connect the yellow wire to the binding post already carrying a yellow wire.
7. Connect the brown wire to the binding post already carrying one brown and one black wire.
8. Lead the free end of the long black wire attached to the brown terminal of the connector block over to the right of the dash, from there to the frame and connect to the right headlight.
9. Hold this wire under the metal clips already holding the wires to the Ford distributor and the two-wire cable.
10. The two short black wires, 12 inches long, are for grounding the headlights.
11. Run each wire from its headlight connector to the $\frac{1}{4}$ -inch screw under the hood sill just back of the radiator.

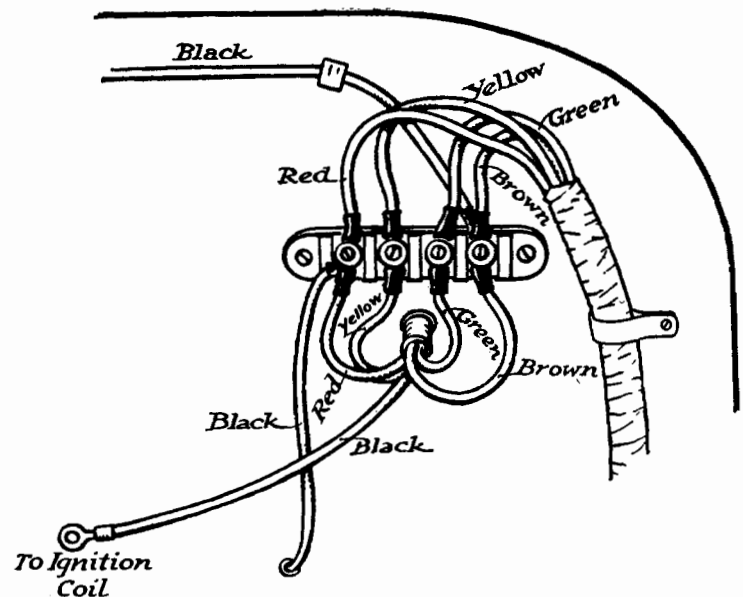

FIG. 17

CONNECTING WIRING ON CONNECTOR BLOCK

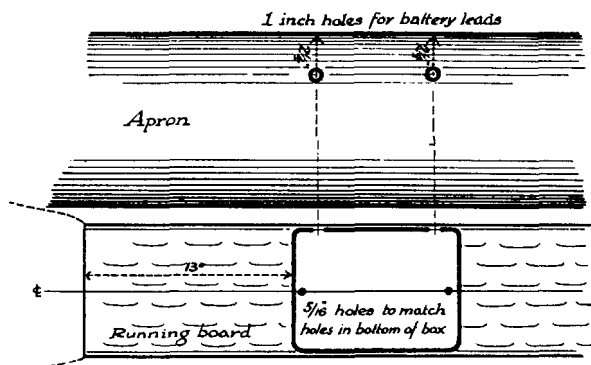

FIG. 18

DIAGRAM FOR BATTERY INSTALLATION

INSTALLING BATTERY

1. Remove battery from battery box.
2. Set battery box on left running board, 13 inches from fender, with the two 1-inch holes facing car.
3. Mark on running board with pencil or chalk position of two 5/16-inch holes in bottom of battery box.
4. Drill corresponding holes in running board.
5. Mark two points on the apron, or splash plate, $2\frac{1}{4}$ inches from the bottom of the car body and directly in line with the two 1-inch holes in the battery box.
6. At these points make two 1-inch holes in the apron.
7. Set battery in box with positive terminal in rear outside corner of box.
8. Pass battery hold-down hooks through cast iron clips over edge of battery *under the handles*.
9. Pass battery hold-down hooks through 5/16-inch holes in bottom of box and running board.
10. Under running board draw up nuts and washers on hold-down hooks.

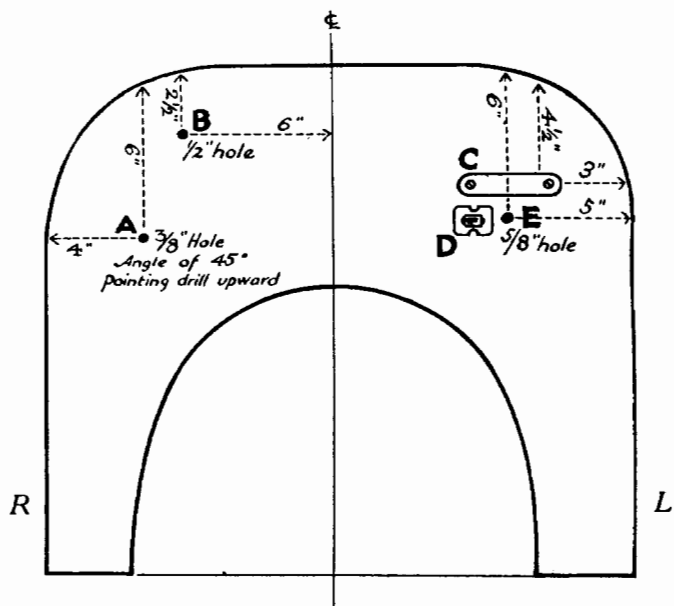

FIG. 11
ENGINE SIDE OF DASH

PREPARING DASH FOR WIRING
(Fig. 11)

1. Five inches from left-hand edge of dash and six inches down from the top, drill a $\frac{5}{8}$ -inch hole (E).

2. Six inches to the right of the center line and $2\frac{1}{2}$ inches down from the top, drill a $\frac{1}{2}$ -inch hole (B).

3. Four inches from the right-hand edge of the dash and six inches down, drill a $\frac{3}{8}$ -inch hole at an angle of 45 degrees. Drill this hole from the engine side of dash, pointing drill upward (A).

4. Three inches from the left-hand edge of the dash and $4\frac{1}{2}$ inches down, place the connector block, fastening it with the two oval-headed wood screws (C).

5. Tack to the dash the cable already attached to connector block as shown in Fig. 12.

6. Take off Ford transformer (D).

7. Cut the two wires at the transformer.

8. Remove lighting switch on steering column by taking out the screw.

9. Pull out the two wires leading to the transformer.

10. Take off the short black wire fastened to the left-hand binding post of the Ford coil.

11. Connect this wire to the binding post on the connector block already carrying a red wire.

12. Entirely disconnect the other wire leading from the left-hand binding post of the Ford coil to the magneto. This wire can be thrown away.

13. Take off the old wires to the lamps.

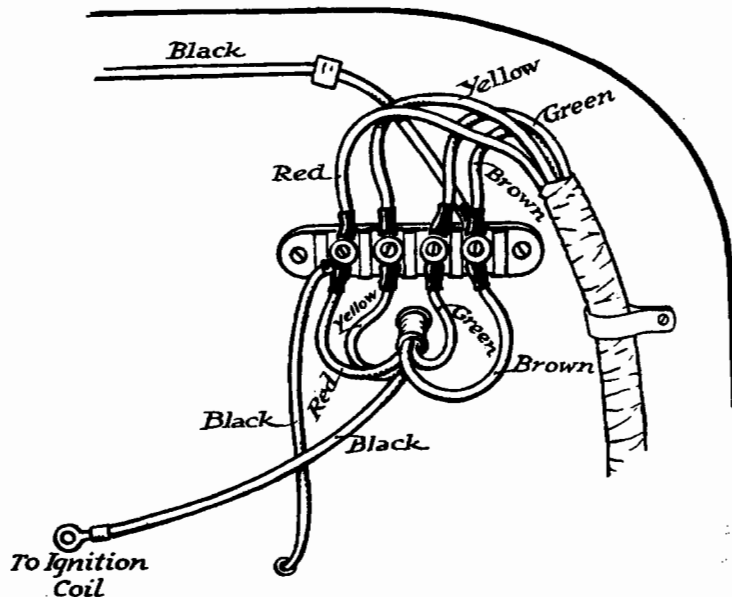

FIG. 12
POSITION OF CONNECTOR BLOCK AND FOUR-WIRE
CABLE

OPERATION OF STARTING MOTOR

1. Be sure that transmission gears are in neutral.
2. Turn on ignition switch.
3. Set spark and throttle exactly as for hand cranking.
4. Press down starting pedal as far as it will go.
5. Remove foot from pedal as soon as engine starts.

Do *not* press starting pedal while engine is running.

Use starting motor for *necessary starting only*. Playing with starter or running the car by the starting motor will ruin the battery and make the whole system useless.

LUBRICATION

Two drops of oil in starter and generator oil cups every two thousand miles ensure perfect lubrication.

GENERATOR

1. Examine brushes occasionally for wear. When fitting new brushes see that they are firmly connected and properly shaped for the commutator.
2. See that brush tension is moderate.
3. If commutator is coated or dirty, remedy by holding a clean cloth against commutator while running.
4. If commutator is rough, hold very fine sandpaper, 00 or finer, against commutator while running. Never use emery.

The small 5-ampere fuse in the terminal block of the generator protects the field windings if the main wire from generator to battery becomes disconnected or broken.

If this fuse blows, correct first of all the difficulty in the wiring connections and then replace with a genuine Atwater Kent fuse. The use of a makeshift will cause serious damage to the generator.

STARTING MOTOR

The bendix drive should give no difficulty, but if oil gums on the shaft it may occasionally "stick." Follow directions on Trouble Chart, page 14.

The remainder of the starter is protected from dust and oil by the housing and should present no difficulties.

Every season the service station should make a thorough inspection of the entire system, windings, brushes and connections.

TROUBLE CHART

If starting motor does not turn over:

1. See that terminals on starter, starting switch and battery are tight.
2. Test battery with hydrometer, as directed in battery book.
3. Bendix drive may be sticking. Remove bendix cover and examine drive.

If starting motor turns engine over, but the engine fails to start in a reasonable time, 10 seconds, the difficulty is with the engine, not the starter. Stop wasting the battery current and remedy the engine trouble. Be careful not to leave choke open.

If ammeter shows no charge when speed reaches 15 miles per hour:

1. Go over wiring to generator and battery. Look for loose terminals or worn insulations, causing short-circuits.
2. See that commutator is smooth, clean and free from oil.
3. See that brushes are not worn, are properly shaped and that the tension is correct.

In all cases where under- or over-charging is suspected, consult the nearest service station. The automatic cut-out and the third brush adjustments are made at the factory and should not be touched, except in the rarest of cases, and then only by experienced electricians.

If the battery is cared for properly, the connections and wiring are tight and sound and the rest of system left severely alone, except for the specified lubrication, little, if any, difficulty will be experienced.

Use genuine Atwater Kent parts on all replacements. Imitation parts or parts "to fit Atwater Kent" will not give satisfactory service. The use of substitute brushes instead of the carefully-designed Atwater Kent brush caused on test a loss of 30 per cent. in the generator output.

ATWATER KENT OFFICIAL REPAIR STATIONS

ALABAMA

Birmingham—Electric Garage and Repair Co., 2016 Avenue B.
Montgomery—Johnson Tire Co., cor. Bibb and Moulton Streets.

ARIZONA

Nogales—Western Machinery Co., 321 Morley Avenue.
Phoenix—Western Machinery Co., 326-34 East Washington Street.
Tucson—Western Machinery Co., 135 South 6th Avenue.
Globe—Western Machinery Co., 155 North Broad Street.

ARKANSAS

Little Rock—Arkansas Battery Co., Inc., 412-416 Center Street.

CALIFORNIA

Los Angeles—Electric Equipment Co., Inc., 1240 South Hope Street.
Marysville—George W. Roberts, 324 D Street.
Oakland—Borkman & Wagner, 2509 Broadway.
San Diego—Auto Electrical Equipment Co., 932-34-36 8th Street.
San Francisco—Automotive Service Agency, 1452 Bush Street.
Santa Cruz—George C. Elwood, 335 Pacific Avenue.
Stockton—W. L. Maxwell Co., 209 E. Dorado Street.
Fresno—United Auto Electric Co., 1427 Eye Street.

COLORADO

Denver—Auto Electric Appliance Co., 846 Broadway.
Sterling—Valley Electric Co., 107 S. 2d Street.

CONNECTICUT

Bridgeport—Electric Auto Service & Supply Co., 332-34 Hanover Street.
Hartford—Robert R. Ashwell, 347 Trumbull Street.
New Haven—The New Haven Electric Co., 50 Crown Street.
New London—Garlock & Haynes Co., 90 Main Street.

FLORIDA

Jacksonville—Magneto Exchange, 221 W. Adams Street.
Miami—Electric Garage Co., 320 13th Street.
Tampa—G. Norman Baughman Co., 610 Tampa Street.

GEORGIA

Atlanta—Southern Auto Equipment Co., 111 South Forsyth Street.

IDAHO

Boise—Bertram Motor Supply Co., 121 S. 10th Street.

ILLINOIS

Chicago—Pellet Magneto Co., 2453 S. Wabash Avenue.
Peoria—Graham Seltzer Co., 120-122 Main Street.
Rockford—Eric J. Gustafson, 413 S. Winnebago Street.
Springfield—Chapin Electric Garage, 407 E. Jackson Street.

INDIANA

Indianapolis—H. T. Electric Co., 617 N. Capitol Avenue.
Terre Haute—John S. Cox, 222-224 South 7th Street.
Vincennes—Meyers Motor Electric Co., 9 South First Street.

IOWA

Cedar Rapids—Electric Service Co., Inc., 413 Seneca Street.
Davenport—Emeis Mfg. Co., 217-221 Iowa Street.
Fort Dodge—Iowa Electric Starter Service Stations, 25 South 8th Street.
Sioux City—Arthur Electric Co., 715 Pearl Street.

KANSAS

Arkansas City—Mears Bros., 407 S. Summit Street.
Hutchinson—E. H. Helms Electrical Works, 100-102 Sherman Street West.
Salina—Jesse O. Spray, 125-127 North 7th Street.
Topeka—Keele Electric Co., 215 West 6th Street.
Wichita—Goodin Motor Service, 333 South Lawrence Street.

KENTUCKY

Louisville—Rommel-Smith Motor Co., Inc., 901-03 East Broadway.

LOUISIANA

New Orleans—John M. Walton, 700 St. Charles Street.
Shreveport—Henderson's Garage, Spring Street from Travis to Fannin.

MAINE

Portland—Howard B. Chandler, 12 Park Avenue.

MARYLAND

Baltimore—The Magneto & Machine Co., 1031 Cathedral Street.

MASSACHUSETTS

Boston—Atwater Kent Sales Co. of N. E., 883 Boylston Street.
New Bedford—Auto Electric Service Station, 660 Pleasant Street.
Springfield—Krohne's Service Station, 59-69 Pecosin Avenue.
Worcester—Jenkins & Robertson, 69 Central Street.

MICHIGAN

Detroit—Auto Electric & Service Corporation, 11-19 Seldon Avenue.
Grand Rapids—Leon S. Heth Co., 236-238 Ottawa Avenue, N. W.

MINNESOTA

Minneapolis—Reinhard Bros. Co., 13 S. 9th Street.
St. Paul—Electric Mfg. Co., 164-168 West 6th Street.

MISSOURI

Kansas City—Kansas City Battery Co., 1905-1907 McGee Street.
St. Joseph—The Electric Shop, 918 Francis Street.
St. Louis—S. G. Hoffman Magneto Co., 3219 Locust Street.

MONTANA

Billings—Electric Service Station, Inc., 12 North 29th Street.
Lewistown—Electric Service Station, 110 Fourth Avenue, S.

NEBRASKA

Lincoln—Randall & Noll, 317 S. 11th Street.
Omaha—Auto Electric Service Co., 2059 Farnam Street.

NEW HAMPSHIRE

Manchester—E. E. Austin, 123 Canal Street.

NEW JERSEY

Atlantic City—Francis J. McCaffrey, 3333 Atlantic Avenue.
Morristown—Victor A. Wiss & Bro., 12 Pine Street.
Newark—The P. J. Durham Co., Inc., 243-245 Central Avenue.
Trenton—Brock's Garage, Canal Street at State.

NEW YORK

Albany—Autoelectric Equipment & Repair Co., 61 Central Avenue.
Brooklyn—The P. J. Durham Co., Inc., 761 Park Place.
Buffalo—Meinhard Auto Service Co., Main and Virginia Streets.
Ithaca—Davis Brown Electric Co., 115-117 South Cayuga Street.
New York City—E. J. Edmond Co., 1783 Broadway.
Rochester—J. Lawrence Hill Co., Inc., 21-23-25-27-29 Plymouth Avenue.
Syracuse—C. Per Lee Noxon, 243 W. Adams Street.
Utica—Stiefvater Electric Co., 320-322 Lafayette Street.

NORTH DAKOTA

Fargo—Howard B. Tilden, 71 5th Street, North.

OHIO

Akron—A. M. Allen Electric Co., 293-95 Water Street.
Cincinnati—Oskamp Ignition Co., Race and Seventh Streets.
Cleveland—Cleveland Ignition Co., 2026 East 22d Street.
Columbus—Brooks & Co., 64 E. Spring Street.
Dayton—Herbert F. Apple, 427 E. 3d Street.
New Philadelphia—West End Garage, 718-726 West Fair Street.
Toledo—Electric Power Maintenance Co., 1101-1107 Monroe Street.

OKLAHOMA

Tulsa—Underwood's Magneto Exchange, 202 South Boulder Street.
Oklahoma City—Walsh Electric Co., 718 North Broadway.

OREGON

Pendleton—Chase Engineering Co., 320 East Court Street.
Portland—Electric Service Auto Co., 391 Oak Street.

PENNSYLVANIA

Allentown—Auto Electric Co., 12 North Centre Square.
Eric—Electric Battery Construction Co., 206 West 12th Street.
Harrisburg—Front-Market Motor Supply Co., 109 Market Street.
Lancaster—Electric Equipment Co., 44 N. Prince Street.
Philadelphia—Carlille & Doughty, 2530 N. Broad Street.
Pittsburgh—Penn Storage Battery Co., 5750-54 Baum Boulevard.
Reading—Berks Ignition Co., 514 Cherry Street.

RHODE ISLAND

Providence—American Ball Co., 115 Clifford Street.

SOUTH CAROLINA

Charleston—Lobby Engineering Co., 151 Meeting Street.
Columbia—Auto Electric Co., Inc., 1216 Hampton Avenue.

SOUTH DAKOTA

Mitchell—Mitchell Auto & Supply Co., 509 N. Main Street.

TENNESSEE

Chattanooga—Southern Auto Supply Co., 613-615 Broad Street.
Knoxville—McNutt & Co., 317 West Cumberland Avenue.
Memphis—Bluff City Electric Co., 26 S. 2d Street.

TEXAS

Amarillo—T. M. Caldwell Co., 110 West Fifth Street.
Abilene—Carter's Auto Repair Shop, 5th and Pine Streets.
Dallas—Dallas Prest-O-Battery & Service Co., Bryan and Hardwood Streets.
El Paso—Western Battery & Magneto Co., 314 E. Boulevard Street.
Fort Worth—Starter Service Co., 283 W. 10th Street.
Houston—Hulbert Still Electric Co., Capitol Avenue and Fannin Street.
San Antonio—S. X. Callahan, 419 N. Flores Street.

UTAH

Salt Lake City—Inter-Mountain Electric Co., 43-59 East 4th Street South.

VIRGINIA

Norfolk—Reliance Elec. Co., 711 Granby Street.
Richmond—The Auto Electric Company, 916 W. Broad Street.

WASHINGTON

Seattle—Sunset Electric Co., 1507-9-11 Broadway.
Spokane—Washington Magneto Co., Inc., 218-220 Madison Street.
Wenatchee—Chase Engineering Co.
Yakima—Chase Engineering Co., 204 W. Yakima Avenue.

WISCONSIN

Madison—Automotive Electric Service Co., 124-126 West Main Street.
Milwaukee—Lemke Electric Co., 513 Cedar Street.

CANADA

Calgary, Alberta—Electric Service Co., 311 17th Avenue, W.
Montreal, Quebec—International Electric Co., 97 Bleury Street.
Regina, Sask.—Western Motor Supplies, Ltd.
Toronto, Ont.—Auto Electric Service Co., Ltd., 10 Elm Street.
Winnipeg—Motor Products, Ltd., Travellers Building.
Vancouver, B. C.—Electric Maintenance Co., 737 Pender Street, W.